

YARIKLI PİM

HEAVY DUTY SPRING PINS

SPANNSTIFTE

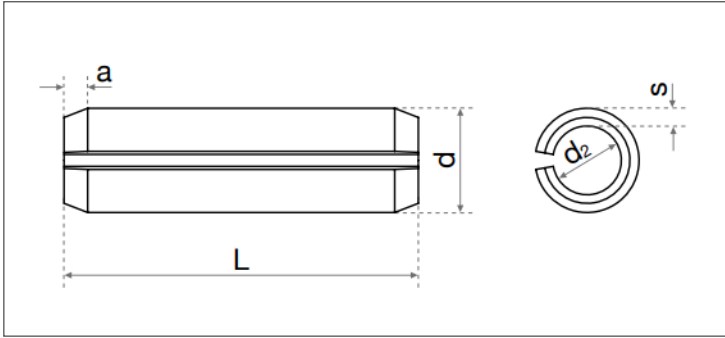

ISO	UNI	DIN
8752	6873	1481
Mekanik Özellikler - Toleranslar Mechanical Properties - Tolerances Mechanische Eigenschaften - Toleranzen		DIN 267-5 UNI 6830

TEKNİK BİLGİLER

TECHNICAL INFORMATION

TECHNISCHE INFORMATION

d		1	1,5	2	2,5	3	3,5	4	5	6	8	10	12	13
d1	max	1,30	5,00	2,40	2,90	3,50	4,00	4,60	5,60	6,70	8,80	10,80	12,80	13,80
	min	1,20	1,70	2,30	2,80	3,30	3,80	4,40	5,40	6,40	8,50	10,50	12,50	13,50
d2	~	0,80	1,10	1,50	1,80	2,10	2,30	2,80	3,40	3,90	5,50	6,50	7,50	8,50
s	~	0,20	0,30	0,40	0,50	0,60	0,75	0,80	1,00	1,25	1,50	2,00	2,50	2,50
a	~	0,15	0,25	0,35	0,40	0,50	0,60	0,65	0,90	1,20	2,00	2,00	2,00	2,00

l		1	1,5	2	2,5	3	3,5	4	5	6	8	10	11	12	
4	+ 0,5 0	0,015	0,034	0,061	0,095	0,136	0,197	0,239							
5		0,019	0,043	0,077	0,118	0,170	0,246	0,299	0,471						
6		0,023	0,051	0,092	0,142	0,204	0,296	0,358	0,566						
8		0,031	0,068	0,122	0,189	0,272	0,394	0,478	0,754	1,10					
10	+ 1 0	0,038	0,085	0,153	0,236	0,340	0,493	0,597	0,942	1,38	2,240	3,690	5,550	6,180	
12		0,045	0,103	0,184	0,283	0,407	0,591	0,716	1,130	1,66	2,660	4,430	6,660	7,420	
14		0,052	0,120	0,214	0,330	0,475	0,689	0,836	1,320	1,94	3,13	5,170	7,780	8,660	
16		0,059	0,137	0,244	0,377	0,543	0,788	0,955	1,510	2,21	3,58	5,900	8,890	9,900	
18		0,067	0,154	0,275	0,424	0,611	0,886	1,070	1,700	2,49	4,03	6,640	10,000	11,100	
20		0,076	0,171	0,305	0,471	0,679	0,985	1,190	1,880	2,77	4,48	7,380	11,100	12,400	
22				0,336	0,519	0,746	1,080	1,310	2,070	3,04	4,92	8,120	12,200	13,600	
24				0,367	0,565	0,814	1,180	1,430	2,260	3,32	5,37	8,860	13,300	14,800	
26				0,397	0,613	0,882	1,280	1,550	2,450	3,60	5,82	9,590	14,400	16,100	
28				0,427	0,660	0,950	1,380	1,670	2,640	3,87	6,26	10,300	15,600	17,300	
30				0,458	0,707	1,020	1,480	1,790	2,830	4,15	6,71	11,100	16,700	18,500	
32						1,090	1,580	1,910	3,03	4,43	7,16	11,800	17,800	19,800	
36						1,220	1,770	2,18	3,39	4,98	8,06	13,300	20,000	22,300	
40						1,360	1,970	2,39	3,77	5,54	8,95	14,800	22,200	24,700	
45									2,68	4,24	6,23	10,10	16,600	25,000	27,800
50									2,98	4,71	6,92	11,20	18,40	27,80	30,90
55	+ 1,5 0							3,27	5,18	7,61	12,30	20,30	30,50	34,00	
60								3,57	5,65	8,30	13,40	22,10	33,30	37,10	
70								4,16	6,59	9,69	15,70	25,80	38,90	43,30	
80								4,75	7,54	11,10	18,00	29,50	44,40	49,50	
90									8,45	12,500	20,10	33,20	50,00	55,60	
100								9,37	13,800	22,40	36,90	55,50	61,80		