

INOX BOMBE BAŞLI İMBUS CIVATA

BUTTON HEAD SOCHET SCREWS

LINSENKOPFSCHRAUBE MIT INNENSECHSKANT

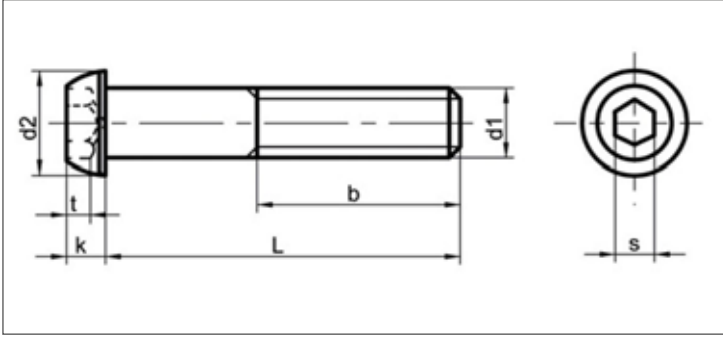

| ISO | UNI | DIN |
|--|-------------|--|
| 7380 | 7380 | 7380 A2/A4 |
| Mekanik Özellikler - Toleranslar Mechanical Properties - Tolerances Mechanische Eigenschaften - Toleranzen | | ISO 3506-1 ISO 4759-1 |

| TEKNIK BİLGİLER | | TECHNICAL INFORMATIONS | | | | TECHNISCHE INFORMATION | | | |
|-----------------|---------|------------------------|------|------|-------|------------------------|-------|-------|--|
| d | | M3 | M4 | M5 | M6 | M8 | M10 | M12 | |
| p | | 0,50 | 0,70 | 0,80 | 1,00 | 1,25 | 1,50 | 1,75 | |
| dk | max | 5,7 | 7,6 | 9,5 | 10,5 | 14 | 17,5 | 21 | |
| | min | 5,40 | 7,24 | 9,14 | 10,07 | 13,57 | 17,07 | 20,48 | |
| k | max | 1,65 | 2,2 | 2,75 | 3,3 | 4,4 | 5,5 | 6,6 | |
| | min | 1,40 | 1,95 | 2,50 | 3,00 | 4,10 | 5,20 | 6,24 | |
| s | nominal | 2 | 2,5 | 3 | 4 | 5 | 6 | 8 | |
| | max | 2,04 | 2,56 | 3,07 | 4,08 | 5,08 | 6,09 | 8,11 | |
| | min | 2,02 | 2,52 | 3,02 | 4,02 | 5,02 | 6,02 | 8,02 | |
| t | min | 1,04 | 1,3 | 1,56 | 2,08 | 2,6 | 3,2 | 4,16 | |
| | | | | | | | | | |
| | | | | | | | | | |

| l | min | max | M3 | M4 | M5 | M6 | M8 | M10 | M12 |
|----|-------|-------|------|------|------|-------|-------|-------|-------|
| 6 | 5,76 | 6,24 | 0,50 | 0,88 | 1,65 | | | | |
| 8 | 7,71 | 8,29 | 0,57 | 1,14 | 1,96 | 3,41 | | | |
| 10 | 9,71 | 10,29 | 0,67 | 1,34 | 2,27 | 3,72 | 7,43 | | |
| 12 | 11,65 | 12,35 | 0,77 | 1,55 | 2,58 | 4,03 | 7,95 | | |
| 14 | 13,65 | 14,35 | 0,88 | 1,75 | 2,89 | 4,34 | 8,46 | | |
| 16 | 15,65 | 16,35 | 0,98 | 1,96 | 3,20 | 4,65 | 9,08 | 16,00 | |
| 18 | 17,65 | 18,35 | 1,08 | 2,17 | 3,51 | 5,01 | 9,81 | 17,20 | |
| 20 | 19,58 | 20,42 | 1,19 | 2,37 | 3,82 | 5,37 | 10,50 | 18,50 | |
| 25 | 24,58 | 25,42 | | 2,89 | 4,54 | 6,40 | 12,90 | 21,70 | 30,50 |
| 30 | 29,58 | 30,42 | | 3,41 | 5,26 | 7,54 | 14,50 | 22,70 | 33,50 |
| 35 | 34,50 | 35,50 | | 3,92 | 5,99 | 8,57 | 16,20 | 26,30 | 37,70 |
| 40 | 39,50 | 40,50 | | | 6,71 | 9,60 | 18,10 | 29,40 | 41,30 |
| 45 | 44,50 | 45,50 | | | | 10,60 | 19,90 | 32,50 | 46,50 |
| 50 | 49,50 | 50,50 | | | | 11,70 | 21,80 | 35,60 | 51,60 |
| 55 | 54,40 | 55,60 | | | | 12,70 | 23,60 | | |
| 60 | 59,40 | 60,60 | | | | 13,70 | 25,50 | 41,80 | 61,90 |
| | | | | | | | | | |
| | | | | | | | | | |
| | | | | | | | | | |
| | | | | | | | | | |
| | | | | | | | | | |
| | | | | | | | | | |
| | | | | | | | | | |
| | | | | | | | | | |
| | | | | | | | | | |
| | | | | | | | | | |
| | | | | | | | | | |
| | | | | | | | | | |
| | | | | | | | | | |
| | | | | | | | | | |
| | | | | | | | | | |