

ALTIKÖŞE PUL BAŞLI MATKAPUÇLU VİDA

HEXAGON WASHER HEAD SELF DRILLING SCREW

SECHSKANT-SELBSTBOHRENDE SCHRAUBE MIT BUND

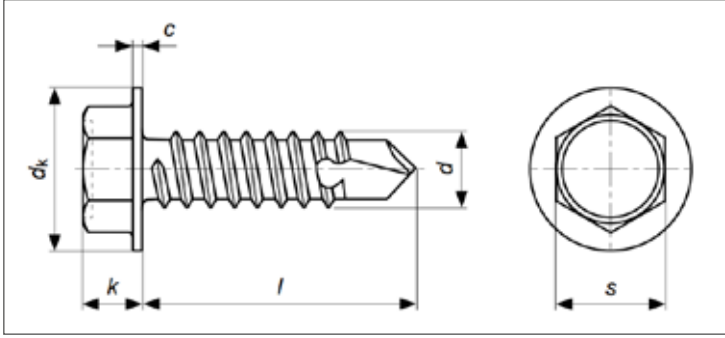

ISO	UNI	DIN
15480	8117	7504K
Mekanik Özellikler - Toleranslar Mechanical Properties - Tolerances Mechanische Eigenschaften - Toleranzen		ISO 10666 ISO 4759-1

TEKNİK BİLGİLER

TECHNICAL INFORMATIONS

TECHNISCHE INFORMATION

d		3,5	3,9	4,2	4,8	5,5	6,3
K	max	5,00	3,45	4,10	4,30	5,40	5,90
	min	3,00	3,20	3,60	3,80	4,80	5,30
dk	max	8,30	8,30	8,80	10,50	11,00	13,50
	min	7,60	7,60	8,10	9,80	10,00	12,20
c	min	0,60	0,60	0,80	0,90	1,00	1,00
N°	MG Drv No NST Recess No	5,5	5,5	7	8	8	10
s	max	5,50	5,50	7,00	8,00	8,00	10,00
	min	5,32	5,32	6,78	7,78	7,78	9,78
Plaka/Levha Kalınlığı Steel Thickness	max	2,25	2,40	3,00	4,40	5,25	6,00
	min	0,70	1,00	1,75	1,75	1,75	2,00

l	min	max	3,5	3,9	4,2	4,8	5,5	6,3
9,5	8,75	10,25	1,20					
13	12,10	13,90	1,35	1,45	1,70	2,60		
16	15,10	16,90	1,45	1,60	1,85	2,90	3,60	
19	18,00	20,00	1,70	1,88	2,10	3,20	4,00	5,80
22	21,00	23,00		2,07	2,30	3,60	4,50	6,40
25	24,00	26,00		2,29	2,50	3,90	4,90	7,00
32	30,75	33,25		2,70	3,00	4,20	5,90	7,60
38	36,75	39,25			3,50	4,60	6,80	9,00
45	43,75	46,25				5,00	7,75	10,10
50	48,75	51,25				5,30	8,50	11,50
55							10,00	12,50
60	58,80	61,20						13,70
70	68,80	71,20						14,90
80	78,80	81,20						16,30
90	88,80	91,20						17,70
100	98,80	101,20						19,10
110								20,90
120								22,70
130								24,20
140								25,80
150								27,40
160								28,90
170								30,40
180								31,90
190								33,40
200								34,90