

İNCE KAFA İMBUS CIVATA

BUTTON HEAD SOCHET SCREWS

LINSENKOPFSCHRAUBE MIT INNENSECHSKANT

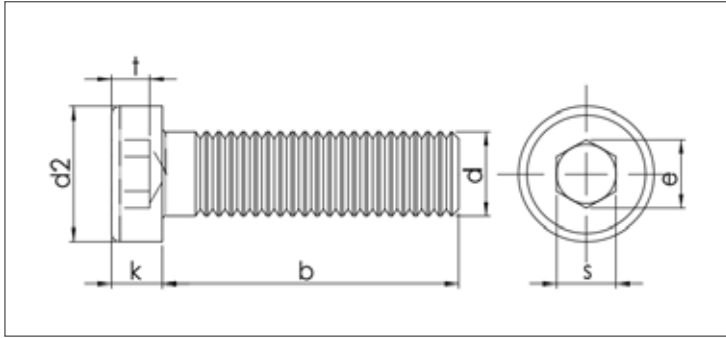

ISO	UNI	DIN
-	9327	7984
Mekanik Özellikler - Toleranslar Mechanical Properties - Tolerances Mechanische Eigenschaften - Toleranzen		898-1 ISO 4759-1

TEKNIK BİLGİLER

TECHNICAL INFORMATION

TECHNISCHE INFORMATION

d		M4	M5	M6	M8	M10	M12	M16
p								
dk	max	7,00	8,50	10,00	13,00	16,00	18,00	24,00
	min	6,78	8,28	9,78	12,73	15,73	17,73	23,67
k	max	2,80	3,50	4,00	5,00	6,00	7,00	9,00
	min	2,66	3,32	3,82	4,82	5,82	6,78	8,78
s	nominal	2,50	3,00	4,00	5,00	7,00	8,00	12,00
	min	2,52	3,02	4,02	5,02	7,02	8,02	12,03
	max	2,60	3,10	4,12	5,14	7,17	8,17	12,21
e	min	2,87	3,44	4,58	5,72	8,01	9,15	11,43
	nominal	2,30	2,70	3,00	3,80	4,50	5,00	5,50
t	min	2,18	2,58	2,88	3,65	4,35	4,85	5,35
	max	2,42	2,82	3,12	3,95	4,65	5,15	5,65
b	b l ≤ 125	14,00	16,00	18,00	22,00	26,00	30,00	38,00
	b l >125 (125<l≤ 200)				28,00	32,00	36,00	44,00
	b l > 200							57,00

l	min	max	M4	M5	M6	M8	M10	M12	M16
6	5,76	6,24	0,96						
8	7,71	8,29	1,12	2,26					
10	9,71	10,29	1,28	2,50	3,59				
12	11,65	12,35	1,44	2,74	3,94	8,06			
14	13,65	14,35	1,60	2,98	4,29	8,06			
16	15,65	16,35	1,76	3,22	4,64	9,25	14,40		
18	17,65	18,35	1,95	3,46	4,99	9,85	15,40		
20	19,58	20,42	2,15	3,77	5,34	10,50	16,40	24,10	
25	24,58	25,42	2,64	4,54	6,45	12,00	19,00	27,70	
30	29,58	30,42		5,31	7,56	14,00	21,60	31,30	62,10
35	34,50	35,50			8,67	16,00	24,70	34,90	68,80
40	39,50	40,50			9,78	18,00	27,80	39,30	76,50
45	44,50	45,50				20,00	30,90	43,10	82,20
50	49,50	50,50				22,00	34,00	48,70	89,60
55	54,40	55,60				24,00	37,10	52,50	97,00
60	59,40	60,60				26,00	40,20	56,90	104,00
70	69,40	70,60					46,40	65,80	119,00
80	79,40	80,60						74,70	134,00