

ALYAN BAŞLI SETSKUR

FLAT POINT HEXAGON SOCKET SET SCREWS

FLACHSPITZ-INNENSECHSKANT-STELLSCHRAUBEN

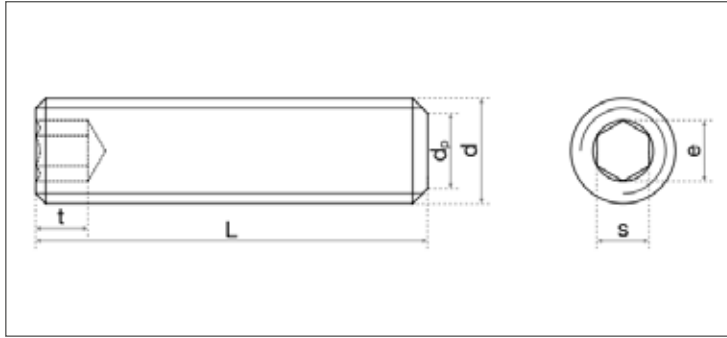

DIN EN ISO	UNI	DIN
4026	5923	913
Mekanik Özellikler - Toleranslar Mechanical Properties - Tolerances Mechanische Eigenschaften - Toleranzen		898-5 ISO 4759-1

TEKNİK BİLGİLER

TECHNICAL INFORMATION

TECHNISCHE INFORMATION

d		M3	M4	M5	M6	M8	M10	M12	M14	M16
p		0,50	0,70	0,80	1,00	1,25	1,50	1,75	2,00	2,00
d _p	max	2,00	2,50	3,50	4,00	5,50	7,00	8,50	10,00	12,00
	min	1,75	2,25	3,20	3,70	5,20	6,64	8,14	9,64	11,57
	nominal	1,50	2,00	2,50	3,00	4,00	5,00	6,00	6,00	8,00
s	max	1,54	2,04	2,56	3,08	4,09	5,09	6,09	6,09	8,11
	min	1,52	2,02	2,52	3,02	4,02	5,02	6,02	6,02	8,02
e	min	1,73	2,30	2,87	3,44	4,58	5,72	6,86	6,86	9,15
t	3) min	1,20	1,50	2,00	2,00	3,00	4,00	4,80	5,60	6,40
	4) min	2,00	2,50	3,00	3,50	5,00	6,00	8,00	9,00	10,00

l	min	max	M3	M4	M5	M6	M8	M10	M12	M14	M16
3	2,80	3,20	0,10								
4	3,76	4,24	0,14	0,22							
5	4,76	5,24	0,18	0,31	0,31						
6	5,76	6,24	0,22	0,39	0,57	0,78					
8	7,71	8,29	0,32	0,54	0,82	1,13	1,93				
10	9,71	10,29	0,41	0,69	1,06	1,49	2,57	3,86			
12	11,65	12,35	0,50	0,85	1,31	1,85	3,21	4,88			
14	13,65	14,35	0,55	1,31	1,55	2,12	3,83	5,74	7,75		
16	15,65	16,35	0,68	1,15	1,80	2,56	4,50	6,92	9,79	13,30	15,80
20	19,48	20,42	0,87	1,46	2,28	3,58	5,78	8,94	12,65	17,30	21,90
25	24,58	25,42		1,85	2,90	4,17	7,41	11,42	16,32	22,40	28,60
30	29,58	30,42		2,23	3,51	5,07	9,03	13,97	19,99		35,30
35	34,50	35,50		2,62	4,12	5,97	10,61	16,52	23,66	32,60	41,90
40	39,50	40,50			4,73	6,86	12,24	19,07	27,34		48,70
45	44,50	45,50				7,76	13,84	21,60	31,01		55,30
50	49,50	50,50				8,66	15,45	24,14	34,68		62,00
60	59,40	60,60						29,22	42,02		
70	69,40	70,60						34,30	49,37		
80	79,40	80,60							56,71		